

CIVIL ENGINEERING

Paper – I

Time Allowed : **Three Hours**

Maximum Marks : **200**

Question Paper Specific Instructions

Please read each of the following instructions carefully before attempting questions :

*There are **EIGHT** questions in all, out of which **FIVE** are to be attempted.*

*Questions no. **1** and **5** are **compulsory**. Out of the remaining **SIX** questions, **THREE** are to be attempted selecting at least **ONE** question from each of the two Sections A and B.*

Attempts of questions shall be counted in sequential order. Unless struck off, attempt of a question shall be counted even if attempted partly. Any page or portion of the page left blank in the Question-cum-Answer Booklet must be clearly struck off.

All questions carry equal marks. The number of marks carried by a question/part is indicated against it.

Unless otherwise mentioned, symbols and notations have their usual standard meanings.

Assume suitable data, if necessary and indicate the same clearly.

Neat sketches may be drawn, wherever required.

*Answers must be written in **ENGLISH** only.*

SECTION A

- Q1.** (a) A car as shown in the figure below is being towed at a steady speed up on an inclined plane having an angle of 15° with the horizontal. The car weighs 1635 kg. Show the free body diagram of the car and calculate the supporting force on each wheel and force T.

8

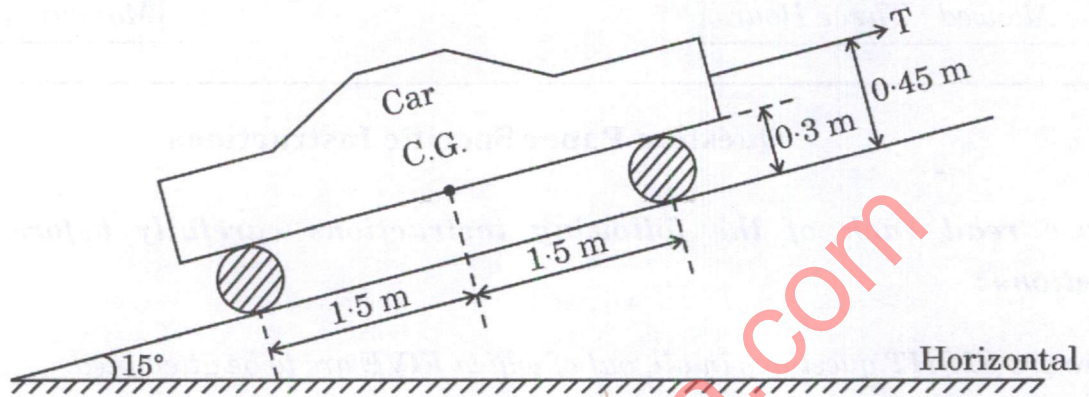

- (b) A steam engine piston of length 80 cm is subjected to a maximum load of 60 kN. If the ends are fixed and the length factor is 0.6, determine the diameter of the piston by using Rankine's formula. Take yield stress as 100 MPa and Rankine's constant as $\frac{1}{7500}$.

8

- (c) A simply supported beam of T-section (flange = 100 mm \times 20 mm and Web = 150 mm \times 10 mm) is 2.5 m in length. It carries a load of 3.2 kN inclined at 20° to the vertical and passing through the centroid of the section. Determine the maximum tensile stress induced in the section.

8

- (d) What is non-conventional prestressing ? Discuss two important non-conventional prestressing methods.

8

- (e) A rectangular prestressed beam of cross-section 175 mm \times 350 mm has an effective span of 12 m. The beam is prestressed by using a cable with zero eccentricity at the supports and linearly varying to 75 mm at the centre. The cable carries a prestressing force of 600 kN. Find the magnitude of the concentrated load located at the centre of the span for the following conditions at a section at the centre of the span :

8

- (i) if the load counteracts the bending effect of prestressing force. Neglect the self-weight of the beam.
- (ii) if the pressure line passes through the upper kern of the section under the action of the external load, self-weight and prestress.

- Q2. (a) A shell is fired from a hill 150 m above a plain. The angle α of firing as shown in the figure below is 20° above the horizontal and the muzzle velocity is 915 m/s. At what horizontal distance, will the shell hit the plain if we neglect the friction of the air. What is the maximum height of the shell above the plain ?

15

Take $g = 10 \text{ m/s}^2$.

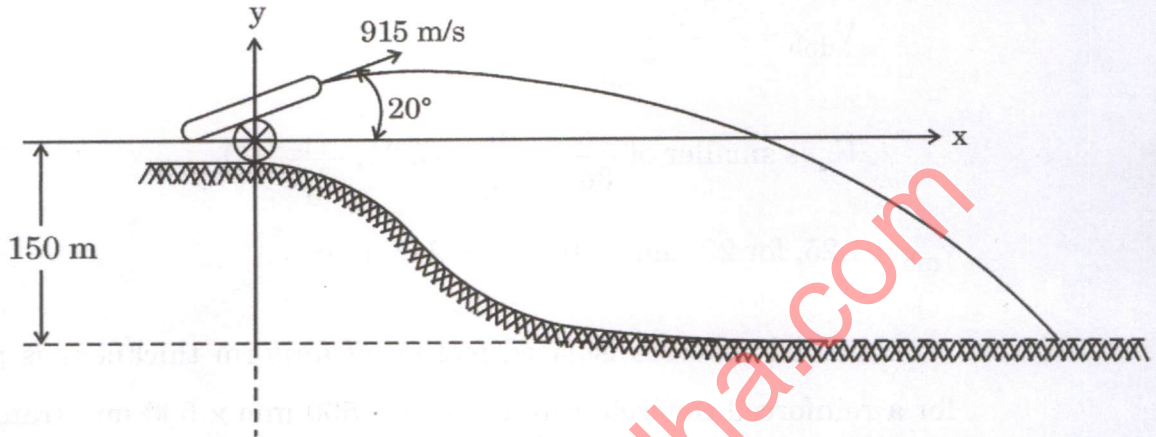

- (b) Determine the safe load 'P' that can be carried by the joint shown in the figure below. The bracket is connected by using 20 mm diameter bolts of grade 4.6. The thickness of the I-section is 9.1 mm and that of bracket plate is 10 mm. Take Fe 410 grade of steel.

15

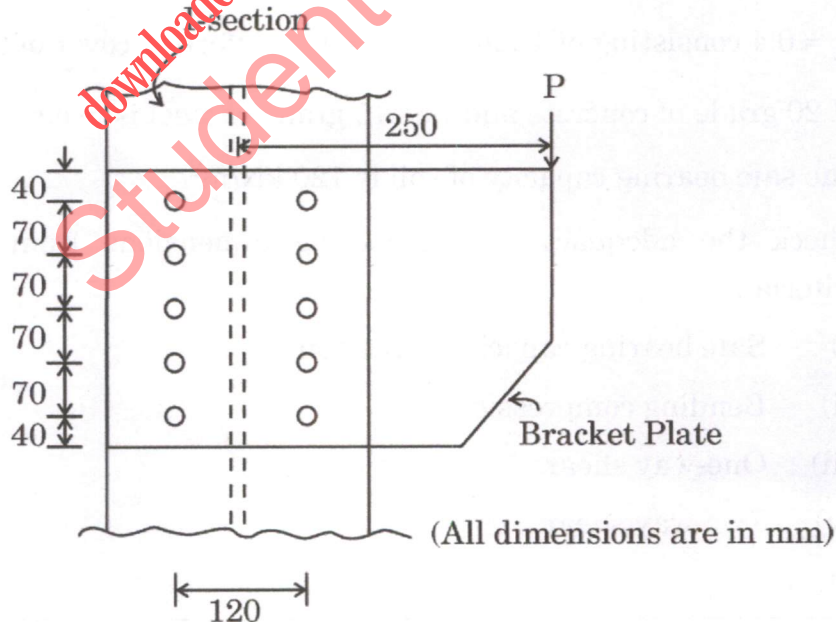

Given :

Design shear strength of bolt

$$V_{dsb} = \frac{f_u}{\sqrt{3} \gamma_{mb}} (n_n A_{nb} + n_s A_{sb})$$

Design bearing strength of bolt

$$V_{dpb} = \frac{2.5 K_b \cdot d \cdot t \cdot f_u}{\gamma_{mb}}$$

$$K_b \text{ is smaller of } \frac{e}{3d_0}, \frac{p}{3d_0} - 0.25, \frac{f_{ub}}{f_u}, 1.0$$

$$\gamma_{mb} = 1.25, \text{ for 20 mm bolts, } A_{nb} = 245 \text{ mm}^2$$

(c) A reinforced concrete isolated footing of uniform thickness is provided for a reinforced concrete column of size 500 mm × 500 mm transmitting an axial load of 600 kN. The details of the footing are as follows :

- (i) Size of footing : 2.4 m × 2.4 m
- (ii) Total depth of footing = 330 mm
- (iii) Reinforcement (%) in either direction

$p_t = 0.4$ consisting of 12 mm ϕ bars with effective cover of 60 mm.

M 20 grade of concrete and Fe 415 grade of steel is used.

The safe bearing capacity of soil is 120 kN/m².

Check the adequacy of the footing dimensions from the following criteria :

10

- (i) Safe bearing capacity of the soil
- (ii) Bending compression
- (iii) One-way shear
- (iv) Two-way shear

Given :

Overall depth of slab, mm	300 or more	275	250	225	200	175	150 or less
K	1.0	1.05	1.10	1.15	1.20	1.25	1.30

Table 19 Design Shear Strength of Concrete, τ_c , N/mm²
(Clauses 40.2.1, 40.2.2, 40.3, 40.4, 40.5.3, 41.3.2, 41.3.3 and 41.4.3)

$100 \frac{A_s}{bd}$	Concrete Grade					
	M 15	M 20	M 25	M 30	M 35	M 40 and above
(1)	(2)	(3)	(4)	(5)	(6)	(7)
≤ 0.15	0.28	0.28	0.29	0.29	0.29	0.30
0.25	0.35	0.36	0.36	0.37	0.37	0.38
0.50	0.46	0.48	0.49	0.50	0.50	0.51
0.75	0.54	0.56	0.57	0.59	0.59	0.60
1.00	0.60	0.62	0.64	0.66	0.67	0.68
1.25	0.64	0.67	0.70	0.71	0.73	0.74
1.50	0.68	0.72	0.74	0.76	0.78	0.79
1.75	0.71	0.75	0.78	0.80	0.82	0.84
2.00	0.71	0.79	0.82	0.84	0.86	0.88
2.25	0.71	0.81	0.85	0.88	0.90	0.92
2.50	0.71	0.82	0.88	0.91	0.93	0.95
2.75	0.71	0.82	0.90	0.94	0.96	0.98
3.00 and above	0.71	0.82	0.92	0.96	0.99	1.01

NOTE — The term A_s is the area of longitudinal tension reinforcement which continues at least one effective depth beyond the section being considered except at support where the full area of tension reinforcement may be used provided the detailing conforms to 26.2.2 and 26.2.3

Table 20 Maximum Shear Stress, $\tau_{c \max}$, N/mm²
(Clauses 40.2.3, 40.2.3.1, 40.5.1 and 41.3.1)

Concrete Grade	M 15	M 20	M 25	M 30	M 35	M 40 and above
$\tau_{c \max}$, N/mm ²	2.5	2.8	3.1	3.5	3.7	4.0

- Q3.** (a) A solid cylindrical shaft is to transmit 300 kW power at 100 rpm. If the shear stress is not to exceed 80 N/mm², find its diameter. What percent saving in weight would be obtained if this shaft is replaced by a hollow one whose internal diameter equals to 0.6 of external diameter, the length, the material and maximum shear stress being the same?

15

- (b) A built-up laced column is made of four angles ISA $100 \times 100 \times 8$ mm placed as shown in the figure. The column carries a factored axial load of 875 kN. The column is 12 m long and both its ends are held in position and restrained against rotation. Double lacing system is used with 20 mm diameter bolts of grade 4.6. Lacings are inclined at 45° and are connected at the centre of leg of the angle section. Find the spacing 'S' of the angle sections and design the lacing system. Connections need not be designed. Take Fe 410 grade of steel.

Given :

Properties of ISA $100 \times 100 \times 8$ mm :

$$A = 1540 \text{ mm}^2$$

$$C_{zz} = C_{yy} = 27.6 \text{ mm}$$

$$r_{zz} = r_{yy} = 30.7 \text{ mm}$$

$$I_{zz} = I_{yy} = 145 \times 10^4 \text{ mm}^4$$

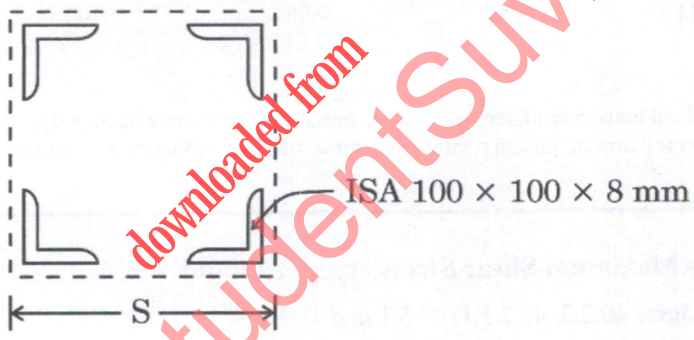

For Q. 3(b)

Table 9(c) Design Compressive Stress, f_{cd} (MPa) for Column Buckling Class c
(Clause 7.1.2.1)

KL/r ↓	Yield Stress, f_y (MPa)																			
	200	210	220	230	240	250	260	280	300	320	340	360	380	400	420	450	480	510	540	
10	182	191	200	209	218	227	236	255	273	291	309	327	345	364	382	409	436	464	491	
20	182	190	199	207	216	224	233	250	266	283	299	316	332	348	364	388	412	435	458	
30	172	180	188	196	204	211	219	234	249	264	278	293	307	321	335	355	376	395	415	
40	163	170	177	184	191	198	205	218	231	244	256	268	280	292	304	320	337	352	367	
50	153	159	165	172	178	183	189	201	212	222	232	242	252	261	270	282	295	306	317	
60	142	148	153	158	163	168	173	182	191	199	207	215	222	228	235	244	252	260	267	
70	131	136	140	144	148	152	156	163	170	176	182	187	192	197	202	208	213	218	223	
80	120	123	127	130	133	136	139	145	149	154	158	162	165	169	172	176	180	183	186	
90	108	111	114	116	119	121	123	127	131	134	137	140	142	144	146	149	152	154	156	
100	97.5	100	102	104	105	107	109	112	114	116	119	120	122	124	125	127	129	131	132	
110	87.3	89.0	90.5	92.0	93.3	94.6	95.7	97.9	100	102	103	104	106	107	108	110	111	112	113	
120	78.2	79.4	80.6	81.7	82.7	83.7	84.6	86.2	87.6	88.9	90.1	91.1	92.1	93.0	93.8	94.9	95.9	96.8	97.6	
130	70.0	71.0	71.9	72.8	73.5	74.3	75.0	76.2	77.3	78.3	79.2	80.0	80.7	81.4	82.0	82.9	83.6	84.3	84.9	
140	62.9	63.6	64.4	65.0	65.6	66.2	66.7	67.7	68.6	69.3	70.0	70.7	71.2	71.8	72.3	72.9	73.5	74.1	74.6	
150	56.6	57.2	57.8	58.3	58.8	59.2	59.7	60.4	61.1	61.7	62.3	62.8	63.3	63.7	64.1	64.6	65.1	65.5	65.9	
160	51.1	51.6	52.1	52.5	52.9	53.3	53.6	54.2	54.8	55.3	55.7	56.1	56.5	56.9	57.2	57.6	58.0	58.4	58.7	
170	46.4	46.8	47.1	47.5	47.8	48.1	48.4	48.9	49.3	49.8	50.1	50.5	50.8	51.1	51.3	51.7	52.0	52.3	52.6	
180	42.2	42.5	42.8	43.1	43.4	43.6	43.9	44.3	44.7	45.0	45.3	45.6	45.8	46.1	46.3	46.6	46.9	47.1	47.3	
190	38.5	38.8	39.0	39.3	39.5	39.7	39.9	40.3	40.6	40.9	41.1	41.4	41.6	41.8	42.0	42.2	42.5	42.7	42.9	
200	35.3	35.5	35.7	35.9	36.1	36.3	36.5	36.8	37.0	37.3	37.5	37.7	37.9	38.1	38.2	38.4	38.6	38.8	39.0	
210	32.4	32.6	32.8	33.0	33.1	33.3	33.4	33.7	33.9	34.1	34.3	34.5	34.7	34.8	34.9	35.1	35.3	35.4	35.6	
220	29.9	30.1	30.2	30.4	30.5	30.6	30.8	31.0	31.2	31.4	31.5	31.7	31.8	31.9	32.1	32.2	32.4	32.5	32.6	
230	27.6	27.8	27.9	28.0	28.2	28.3	28.4	28.6	28.8	28.9	29.1	29.2	29.3	29.4	29.5	29.7	29.8	29.9	30.0	
240	25.6	25.7	25.9	26.0	26.1	26.2	26.3	26.4	26.6	26.7	26.9	27.0	27.1	27.2	27.3	27.4	27.5	27.6	27.7	
250	23.8	23.9	24.0	24.1	24.2	24.3	24.4	24.5	24.7	24.8	24.9	25.0	25.1	25.2	25.3	25.4	25.5	25.6	25.7	

Table 11 Effective Length of Prismatic Compression Members
(Clause 7.2.2)

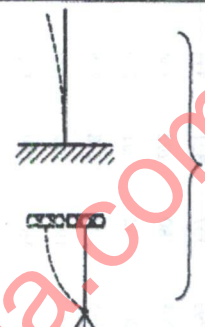
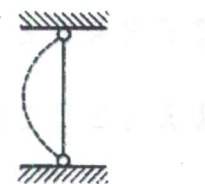
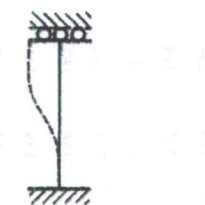
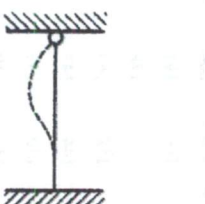
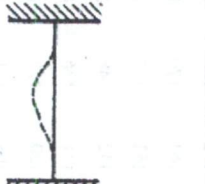
Boundary Conditions				Schematic Representation	Effective Length
At One End		At the Other End			
Translation (1)	Rotation (2)	Translation (3)	Rotation (4)		
Restrained	Restrained	Free	Free		2.0L
Free	Restrained	Free	Restrained		1.0L
Restrained	Free	Restrained	Free		1.2L
Restrained	Restrained	Free	Restrained		0.8L
Restrained	Restrained	Restrained	Free		0.65L

NOTE — L is the unsupported length of the compression member.

- (c) Calculate the moment of resistance of a doubly reinforced T-beam as shown in the figure below. The beam has simply supported span of 5.0 m. Use M 20 grade of concrete and Fe 415 steel.

10

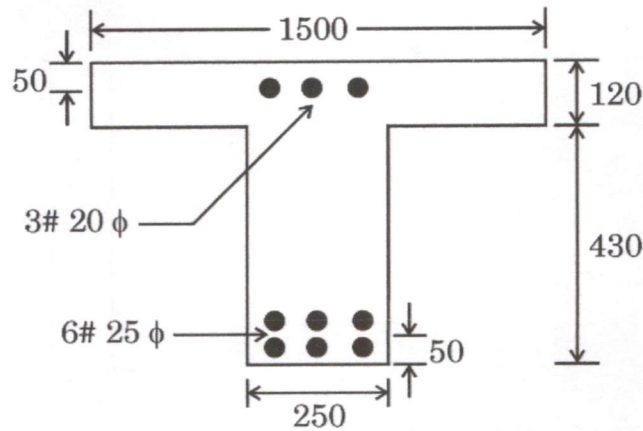

(All dimensions are in mm)

Table 1 : Values from design stress-strain curve for Fe 415 steel :

Stress level	$0.8 \sigma_d$	$0.85 \sigma_d$	$0.9 \sigma_d$	$0.95 \sigma_d$	$0.975 \sigma_d$	$1.0 \sigma_d$
Strain	0.00144	0.00163	0.00192	0.00241	0.00276	0.0038
Stress (N/mm^2)	288.7	306.7	324.8	342.8	351.8	360.9

Table 2 : For 415 steel :

d'/d	0.05	0.10	0.15	0.20
Stress on compression reinforcement, f_{sc} (N/mm^2)	355	353	342	329

- Q4. (a) Analyze the continuous beam shown below by the slope deflection method. Draw the shear force and bending moment diagrams as well as the deflected shape.

15

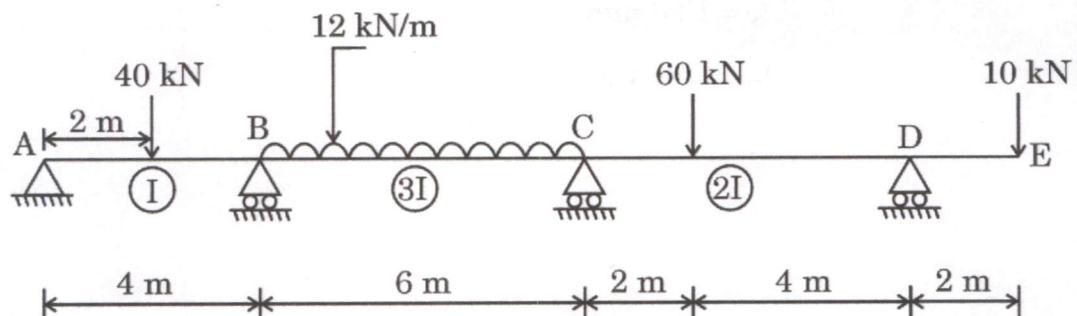

- (b) Find the collapse load for portal frame shown in the figure below. Also draw the free body diagram and bending moment diagram for the frame. 15

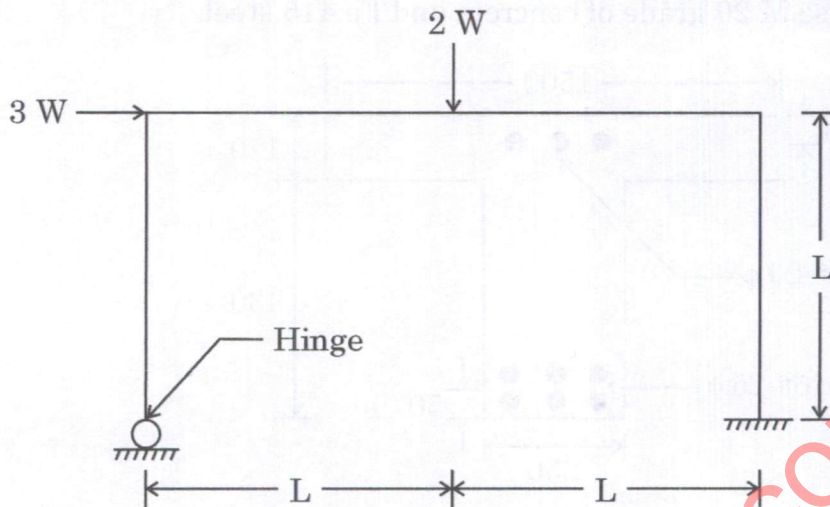

- (c) A tie member consists of two ISMC 300. The channel sections are connected on either side of a 10 mm thick gusset plate. Design a fillet welded joint to develop the full strength of the tie member. The overlap is limited to 300 mm. For the weld, angle between fusion faces is 90° . Draw a neat sketch of the welded connection. Use Fe 410 grade of steel. 10

Given :

- (i) $\gamma_{mf} = 1.1$, $\gamma_{mw} = 1.25$
- (ii) For $60^\circ - 90^\circ$ angle between fusion faces, $K = 0.70$
- (iii) As per codal provisions the width of slot weld should be less than three times the thickness or 25 mm whichever is greater.
- (iv) Properties of ISMC 300 :

$$A = 4563.71 \text{ mm}^2$$

$$t_f = 13.6 \text{ mm}$$

$$t_w = 7.6 \text{ mm}$$

SECTION B

Q5. (a) In a fluid flow the velocity components are given as

$$U = 2xy \quad \text{and} \quad V = a^2 + x^2 - y^2$$

Show that the flow is possible. Obtain the relevant stream function.

8

(b) A double acting reciprocating pump has a piston of diameter 20 cm and the diameter of the piston rod is 5 cm. The length of the stroke is 40 cm and the crank moves at a speed of 80 rpm.

The suction and delivery heads are 3 m and 30 m respectively.

Estimate the discharge capacity of this pump.

If the liquid to be pumped has a specific weight of 8.0 kN/m^3 , estimate the power required to pump the liquid.

Assume pump efficiency as 90% and allow 10% of total lift to account for frictional losses.

8

(c) The liquid limit and plastic limit of a soil are 55% and 22% respectively. When the soil was dried from its state at liquid limit, the decrease in volume was 35% of the volume at liquid limit. When the soil was dried from its state at plastic limit, the volume was decreased by 15% of the volume at plastic limit.

Determine the shrinkage limit and shrinkage ratio.

8

(d) A 6 m thick normally consolidated clay layer underlain by an impermeable layer settles by 80 mm in 2 years. The coefficient of consolidation for this clay was found to be $4.5 \times 10^{-3} \text{ cm}^2/\text{s}$.

Calculate the expected total consolidation settlement of the clay layer.

How long will it take to achieve 75 percent of the total settlement ?

8

(e) A cylindrical soil sample of 38 mm diameter and 76 mm height was tested in an unconfined compression apparatus. If the sample failed at an axial load of 350 N and at an axial compression of 6 mm, find the unconfined compressive strength of the soil.

Also calculate the shear strength parameters of the sample, if the angle made by the failure plane with the horizontal plane was recorded as 55° .

8

- Q6.** (a) Compute the safe bearing capacity of a square footing $2.0 \text{ m} \times 2.0 \text{ m}$ located at a depth of 1.5 m below the ground level in a silty clayey soil with water table at a large depth. Take shear strength parameters $c = 25 \text{ kPa}$ and $\phi = 20^\circ$.

Consider the general shear failure case with a factor of safety = 3.0 .

Also compute the percentage change in the safe bearing capacity if the water table rises to the bottom of the foundation.

Use Terzaghi's theory.

Take $N_c = 17.7$; $N_q = 7.4$ and $N_\gamma = 5.0$.

Density of soil = 17 kN/m^3 above water table

and = 19 kN/m^3 below water table.

15

- (b) (i) Draw a neat sketch of a venturimeter and label its parts.

Is there any restriction on throat diameter of a venturimeter? If so, why?

Why is the length of the diverging cone in a venturimeter more than the length of converging cone?

6+9=15

- (ii) A venturimeter of throat diameter 6 cm is fitted into a 15 cm diameter water pipeline. The coefficient of discharge is 0.95 . Calculate the flow in the pipeline when the reading on a mercury-water differential manometer (U-tube) connected to upstream and throat sections shows a reading of 25 cm . Also find the velocity of flow in the pipe.

- (c) Obtain the total active thrust on a 10 m high retaining wall with a smooth vertical back from a two-layered soil backfill as shown below :

10

(Water table is at a large depth)

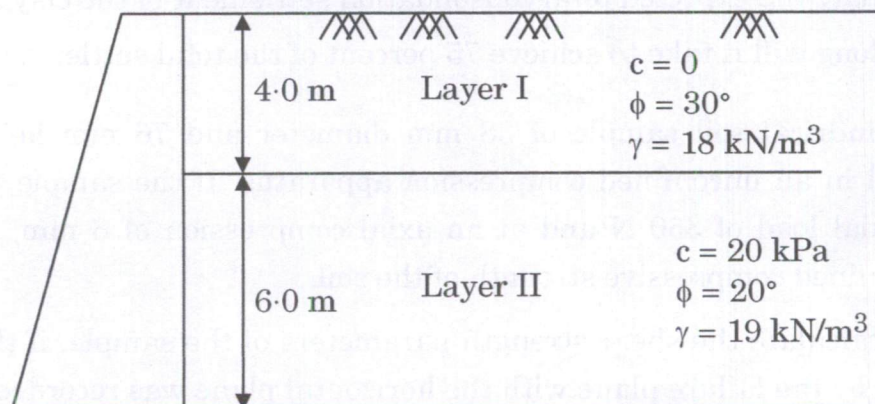

- Q7. (a) A rectangular channel 9 m wide and 2 m deep has a longitudinal slope of 1 in 1000 and is lined with a material having Manning's roughness coefficient of 0.010.

It is proposed to increase the discharge to a maximum by changing the dimensions of the channel but keeping the amount of lining to be the same as before.

Compute the new dimensions of the rectangular channel and also the percentage increase in the discharge. 15

- (b) Three turbo generators each of capacity 8000 kW have been installed at a hydel power station. The load on the plant varies from 10000 kW to 20000 kW. Calculate the total installed capacity, load factor, plant factor and utilisation factor.

What should be the minimum discharge in the stream to generate average load under a head of 30 m ?

Assume plant efficiency as 80%. 10

- (c) Determine the safe load carrying capacity of a 0.45 m diameter \times 10 m long concrete pile to be driven in the following two soil layers :

Assume factor of safety $\gamma = 2.5$. 15

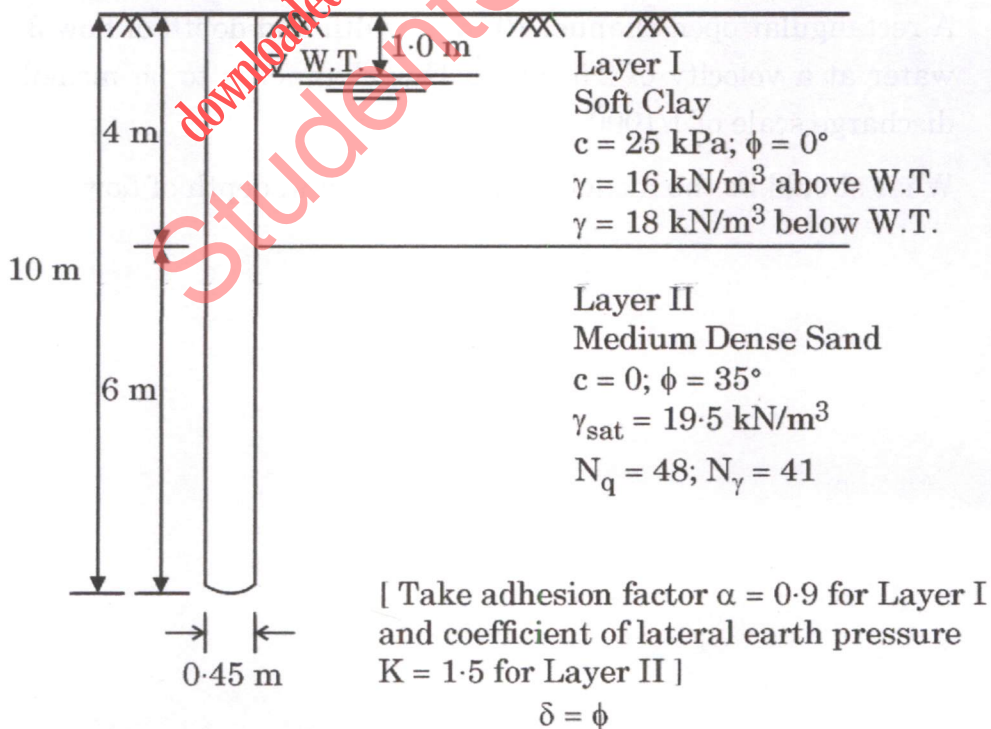

- Q8.** (a) A concentrated load of 100 kN acts on the surface of a soil. Obtain the distribution diagram for increased vertical stress along a vertical line at a radial distance of 1 m from the load axis up to 6 m depth at an interval of 1 m. Also obtain the position and value of the maximum stress.

Use Boussinesq's equation.

15

- (b) A Pelton wheel has two jets and is designed to produce a power of 10000 kW with a net head of 500 m.

The buckets deflect the jet by an angle of 165° .

The reduction of relative velocity due to friction in the buckets can be taken as 20%.

Calculate the total discharge through the turbine, diameter of each jet and the total force exerted by the jets on the wheel in the tangential direction.

Assume overall efficiency as 80%, coefficient of velocity as 0.95 and speed ratio as 0.50.

15

- (c) Explain Geometric similarity, Kinematic similarity and Dynamic similarity as applied to physical model studies.

A rectangular open channel 10 m in width and depth of flow 3 m carries water at a velocity of 2.5 m/sec. This channel is to be modelled with a discharge scale of 1/1000.

What should be the model velocity, width and depth of flow ?

10